

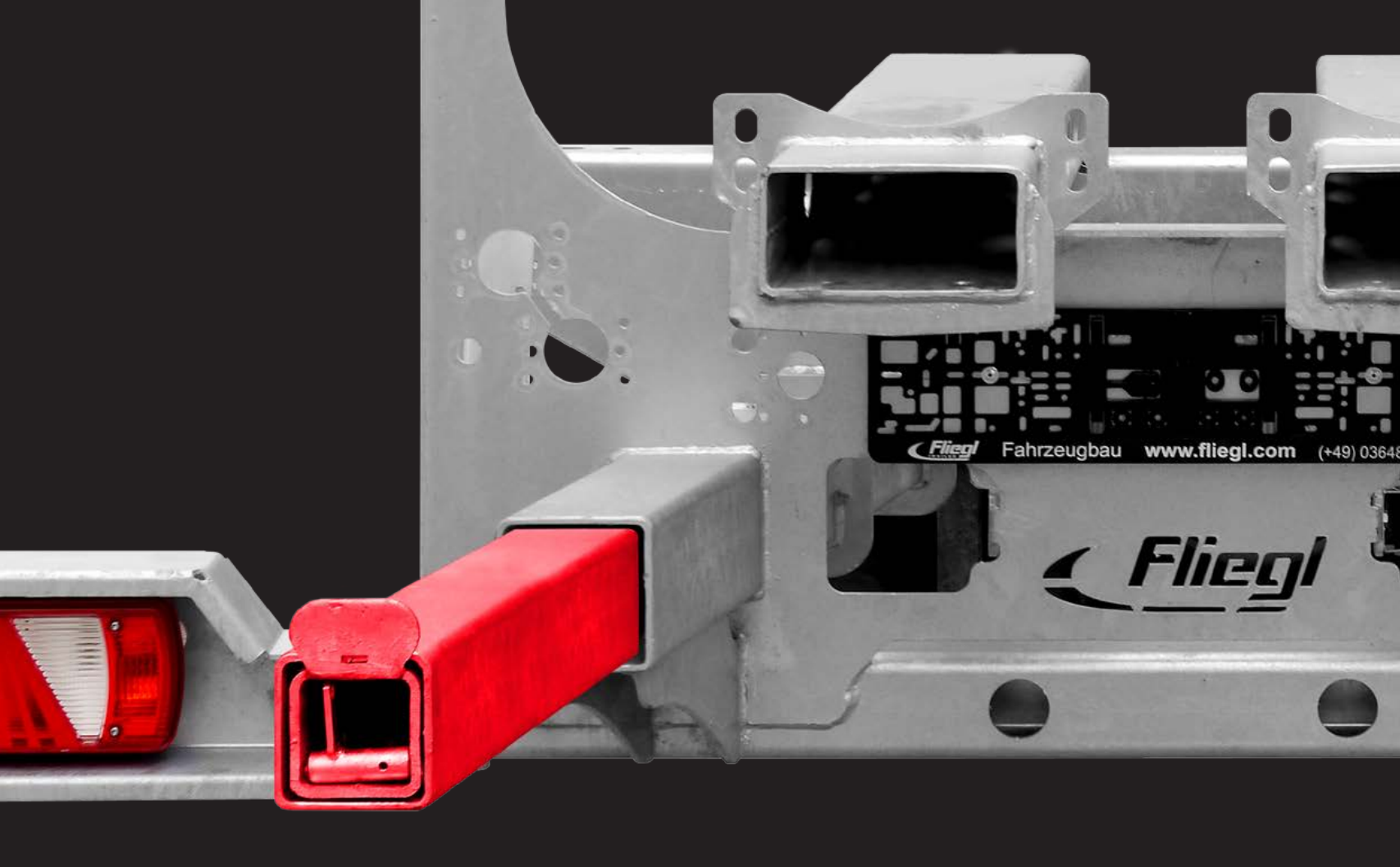

INNOVATING FOR YOU



Fliegl Staplerhalterung

Montage- und Bedienungsanleitung

www.fliegl.com

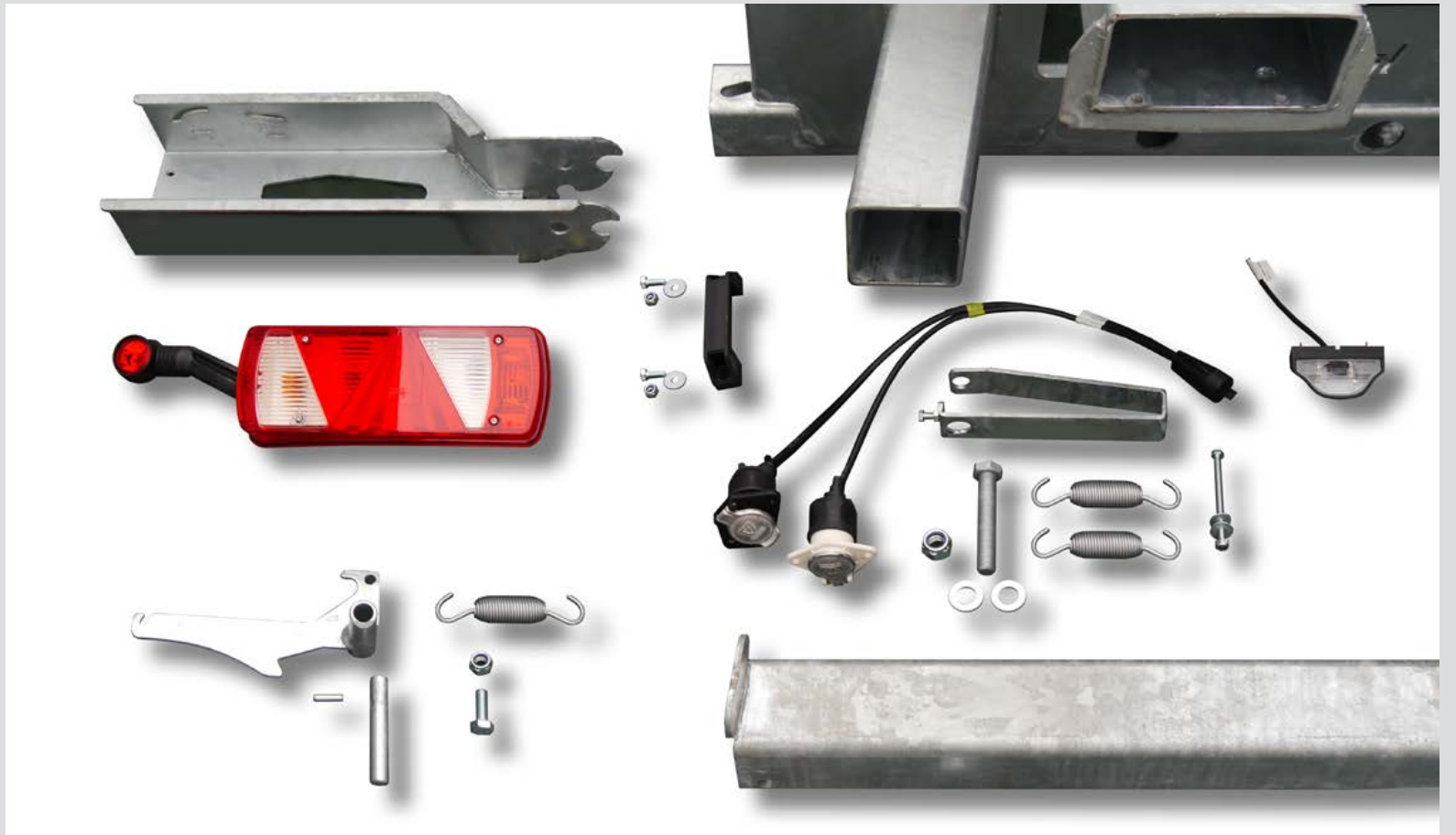

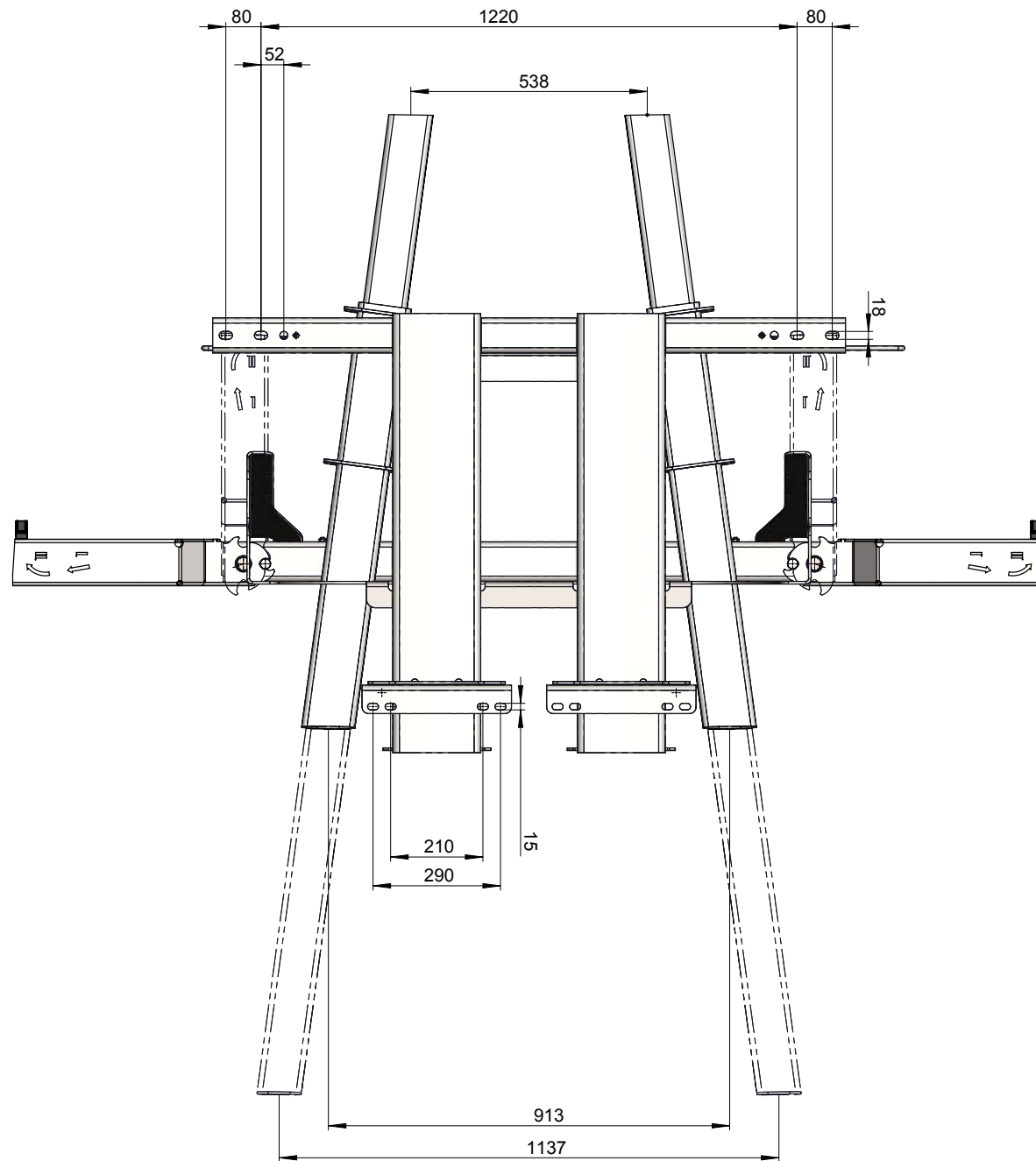

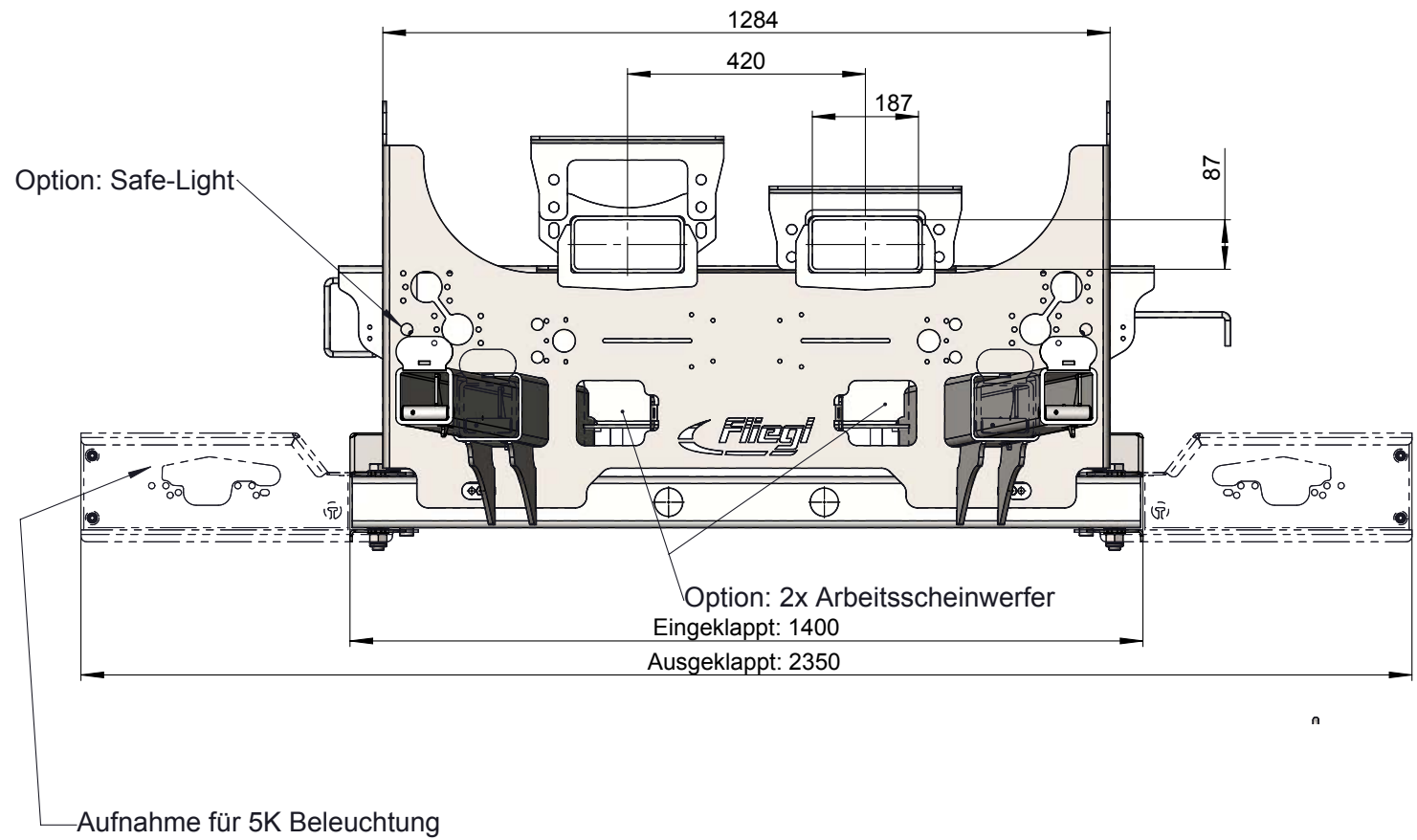

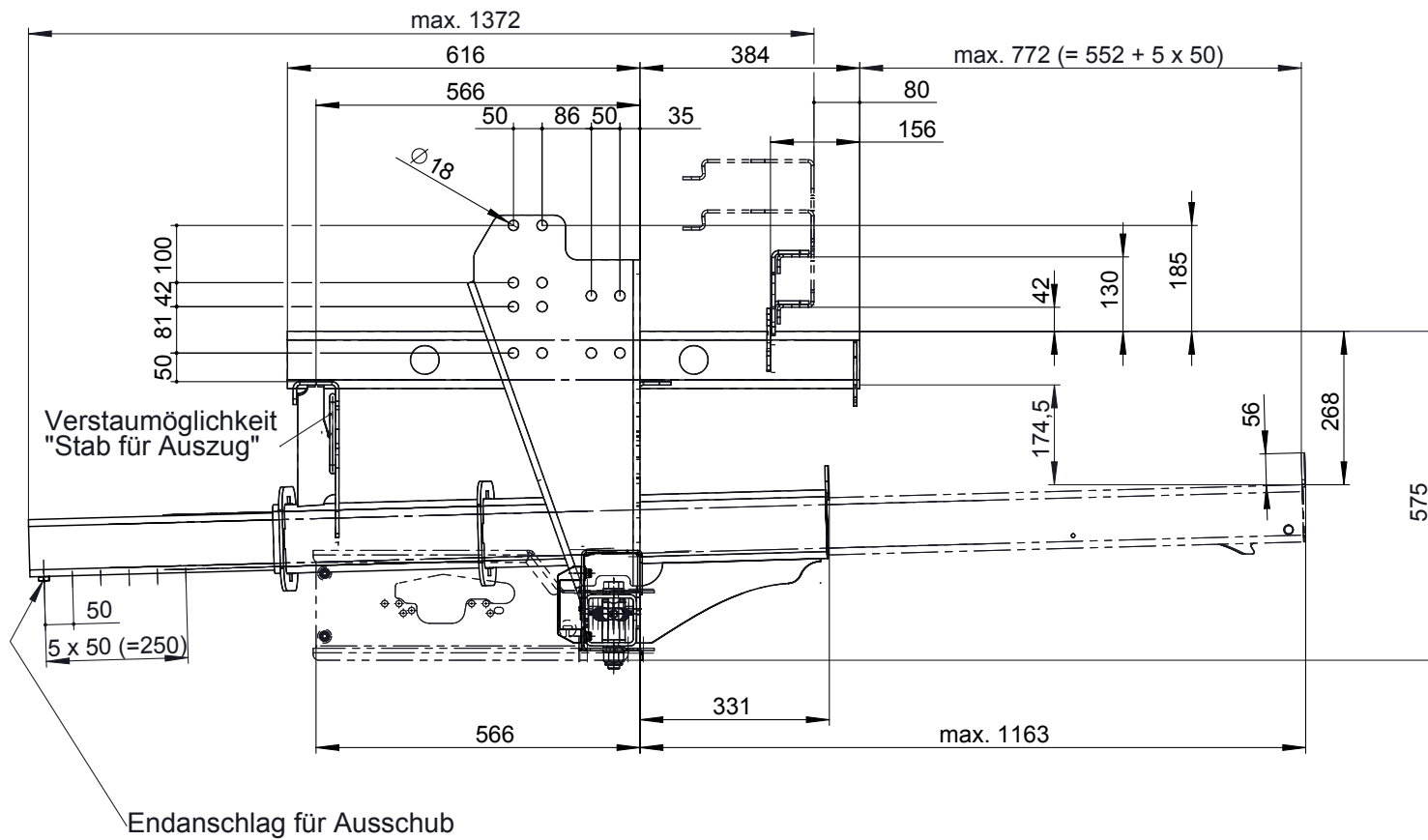

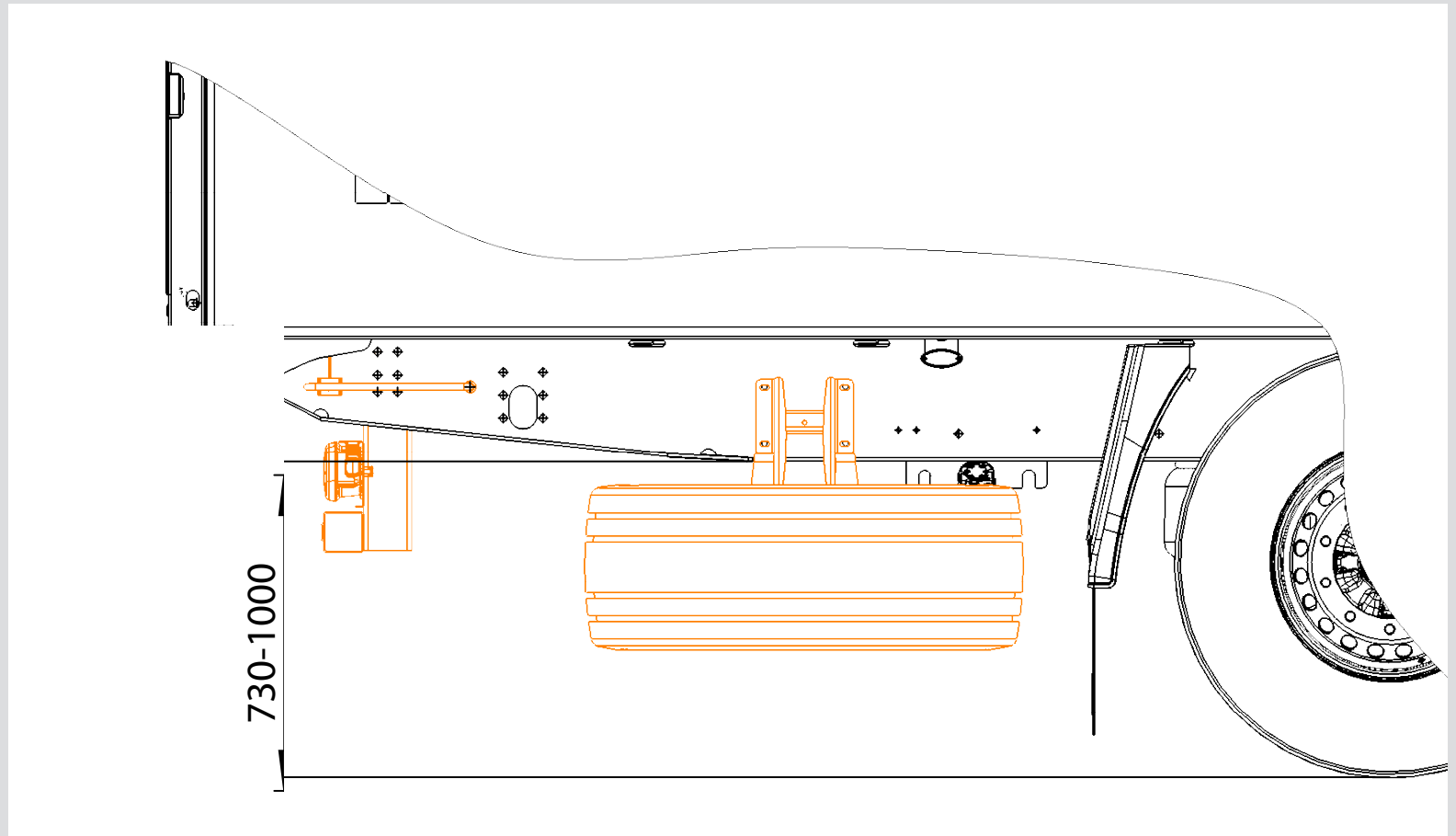

Entfernen der Anbauteile unter dem Heck

- Unterfahrschutz mit Lampenträger
- evtl. Ersatzrad, Staukiste, Bedienblech, Türfeststeller

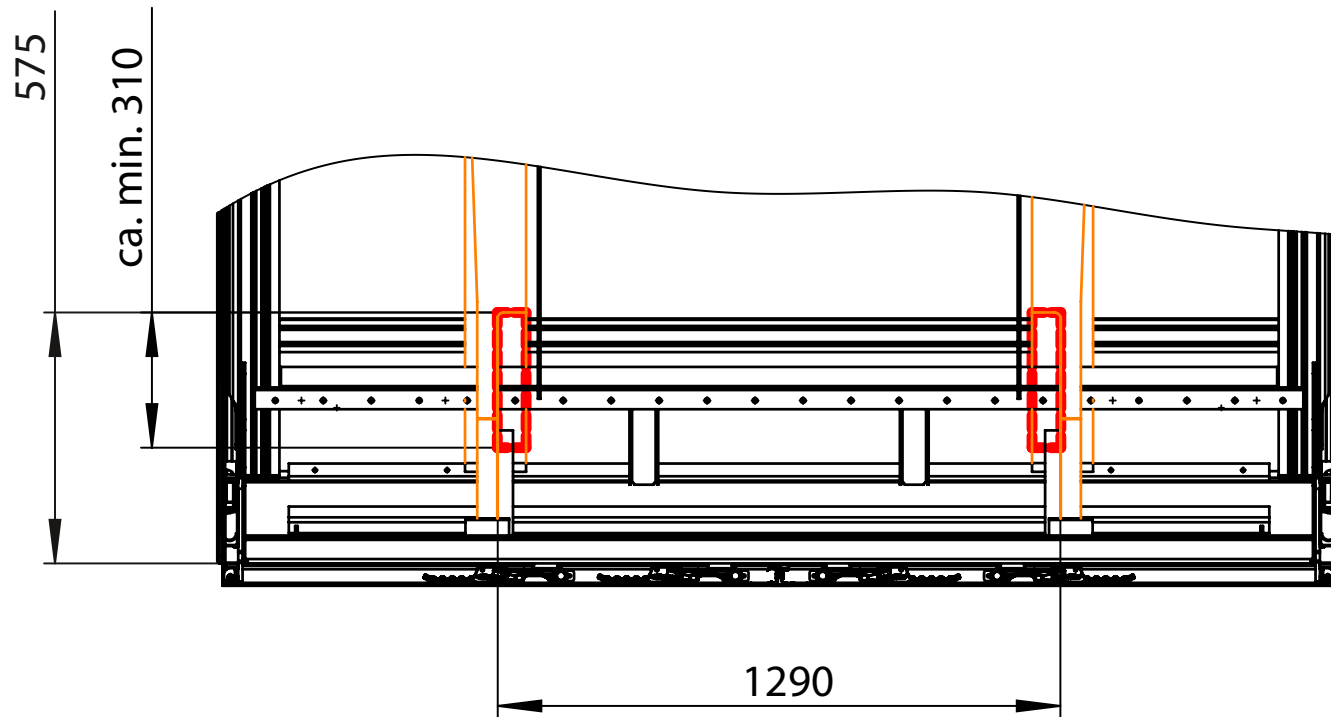

Untergurt von Hauptträger an der Innenseite vom Steg ausklinken
(Stegblech muss an Außenseite Untergurt verschweißt sein)

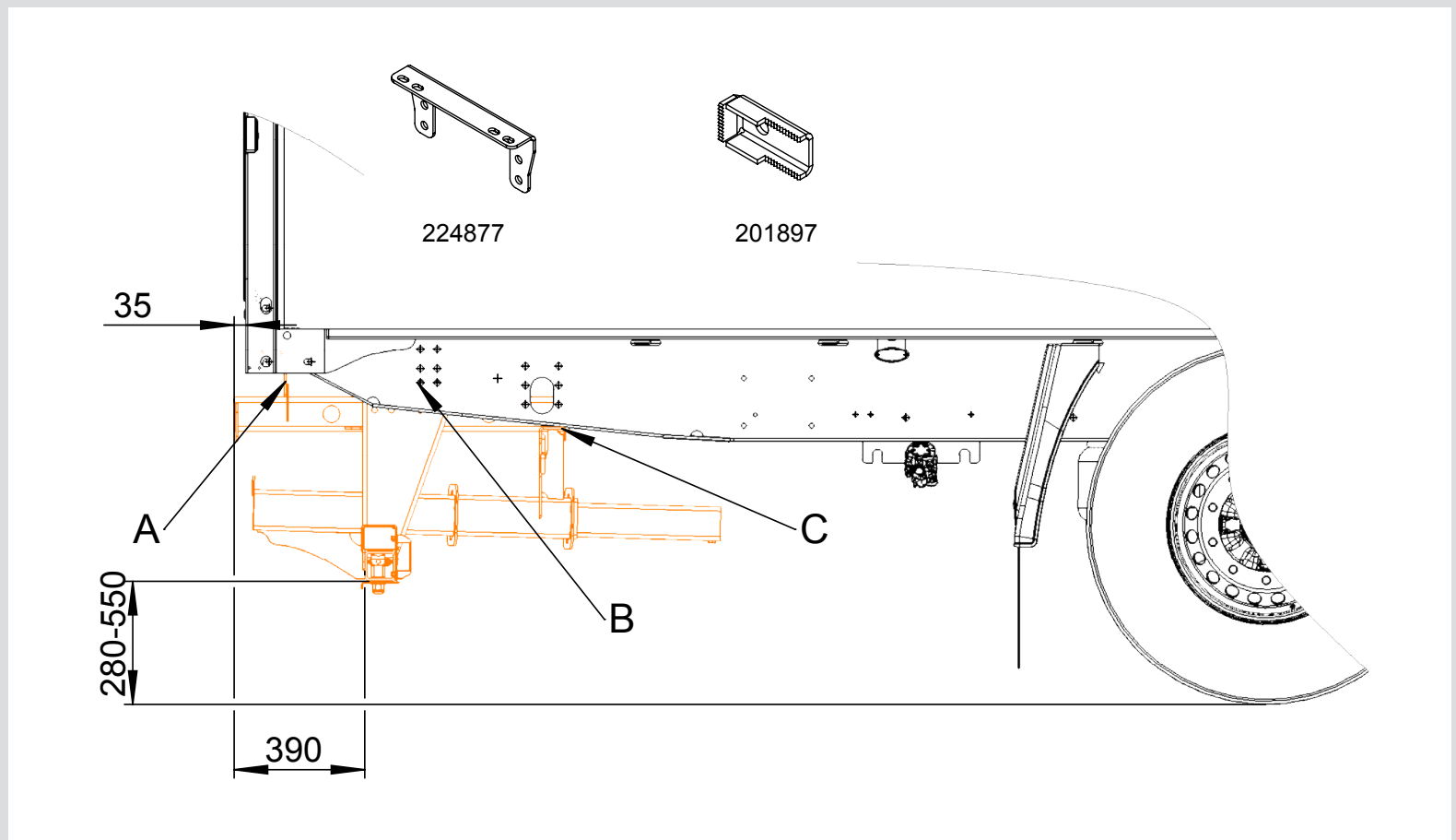

Staplerkonsole an Fahrzeugrahmen verschrauben

A: Mittels Verbindungsblechen Nr. 224877 die Staplerkonsole an den Heckabschluss vom Rahmen verbinden (2 x M12 oben + 2 x M16 je Blech)

B: Mit min. 4 x Verschraubungen pro Seite an Stegblech-Hauptträger verschrauben (M16)

C: mittels 4x Klemmpratzen Nr. 201897 beidseitig an Untergurte Hauptrahmen verschrauben (M16)

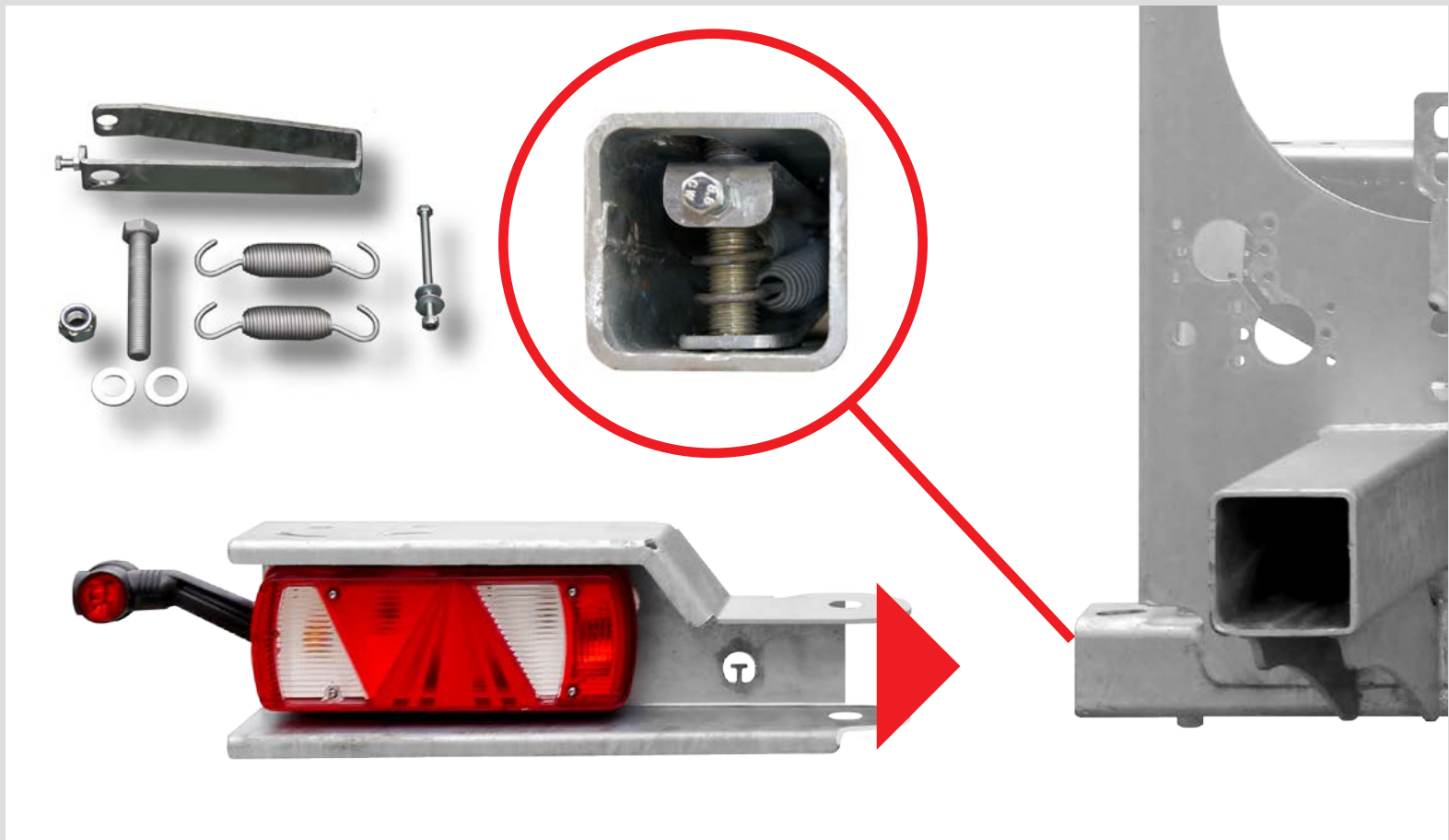

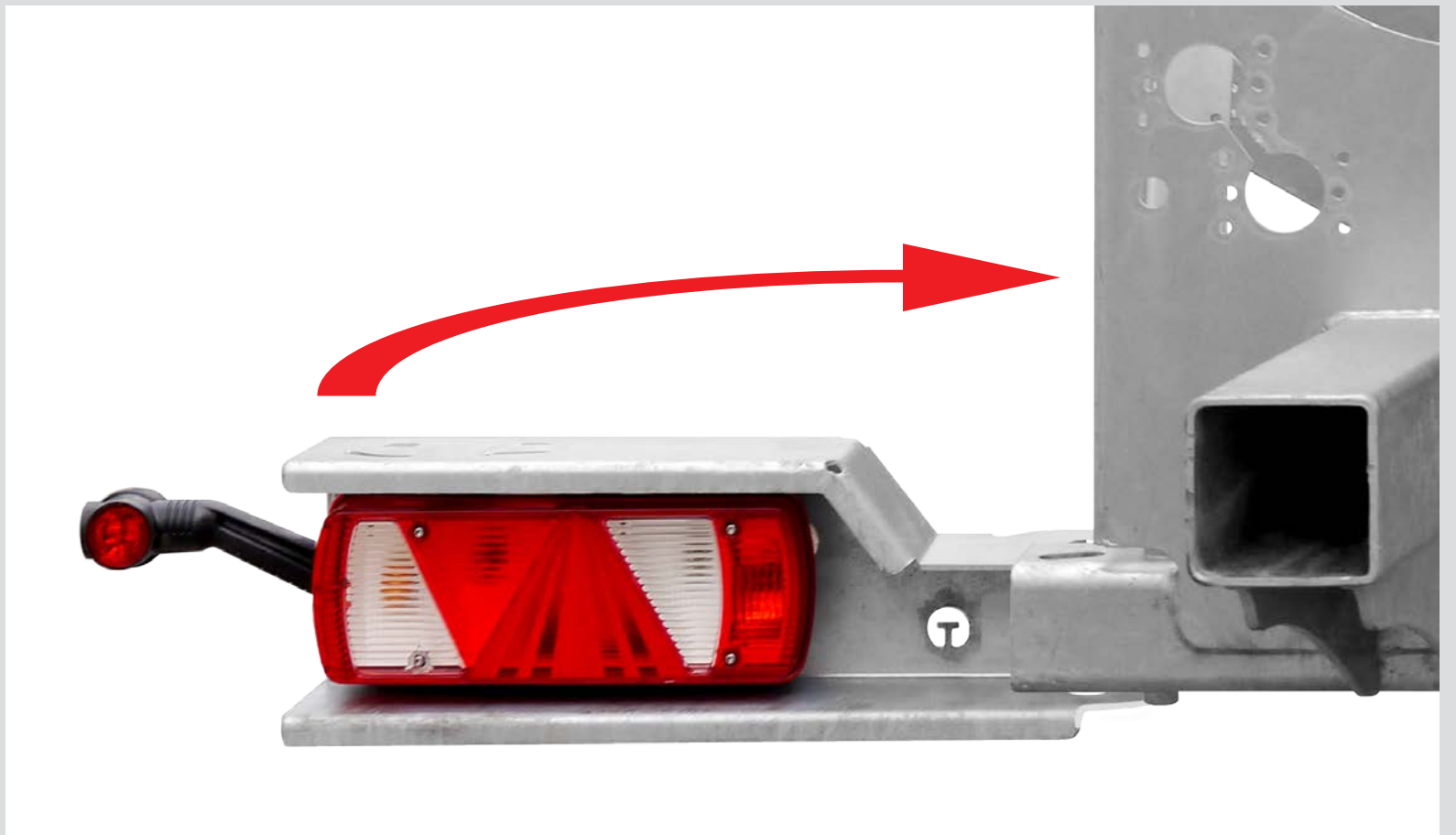

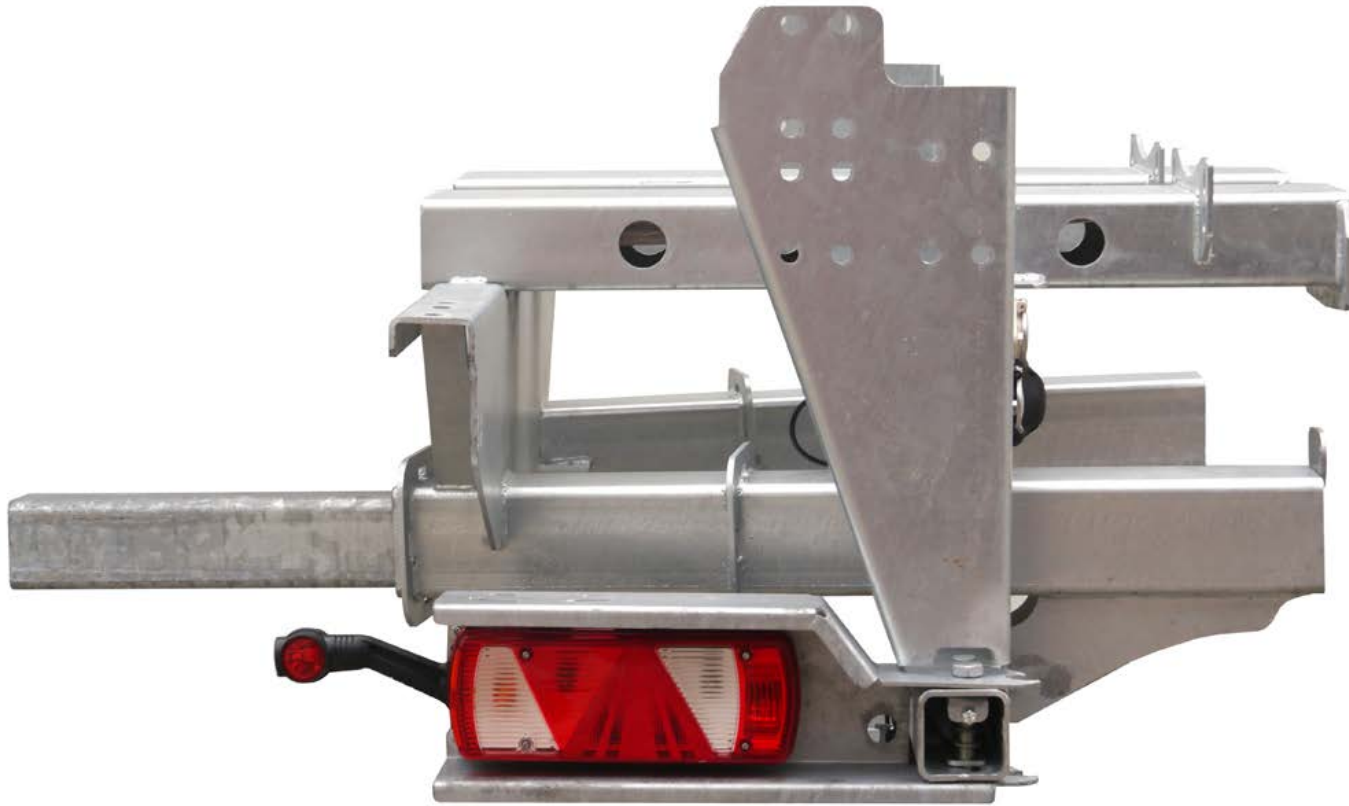



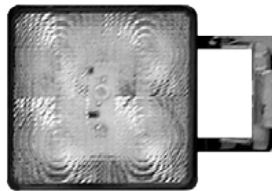
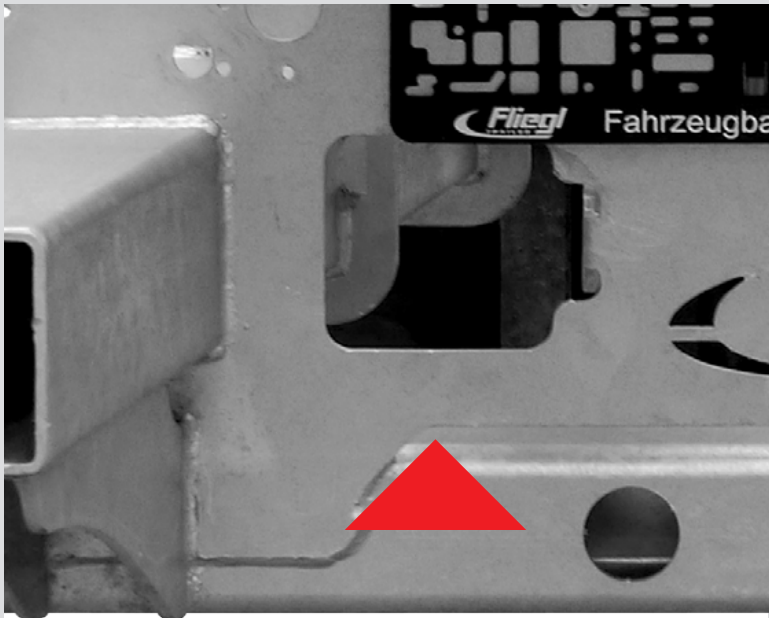



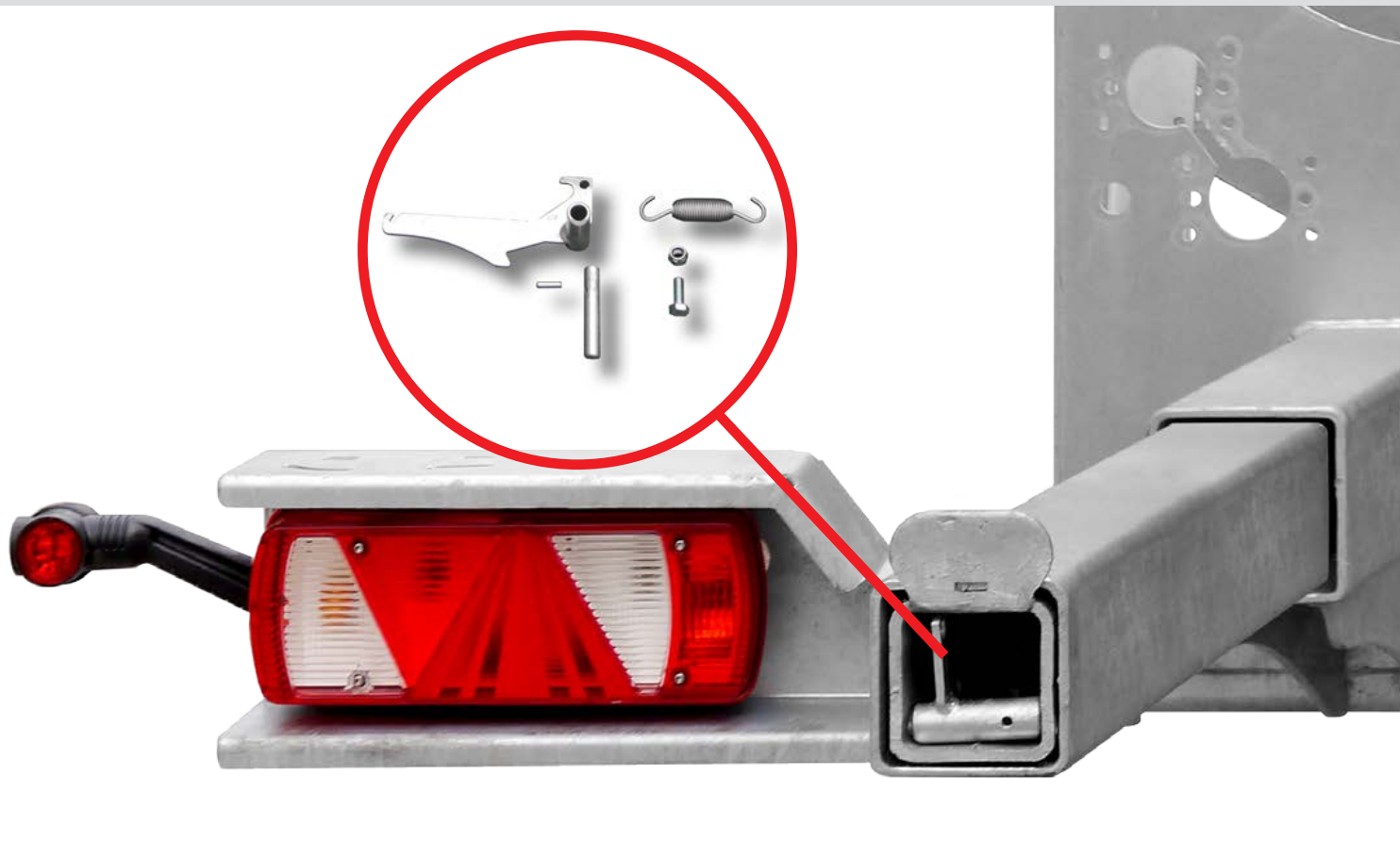



INNOVATING FOR YOU

www.fliegl.com